

ITEM NO.	PART NUMBER	DESCRIPTION	QTY.
1	TL3037	LARGE RING TOP	1
2	TL3086	LARGE RING MIDDLE	1
3	TL3087	LARGE RING BOTTOM	2
4	AA6770	8-32 X 2-3/4 PRHMS	4
5	6031	#8 FLAT WASHER (ZINC)	4
6	6072	8-32 NYLOCK NUT	4
7	6419	6-32 X 1" PEM STUD	16
8	PC60643	6-32 x 1/4 HH SPACER	32
9	TL3014XR	SENSOR PANEL REC	2
10	TL3014XT	SENSOR PANEL TRANS	2
11	E00724_TLC		1

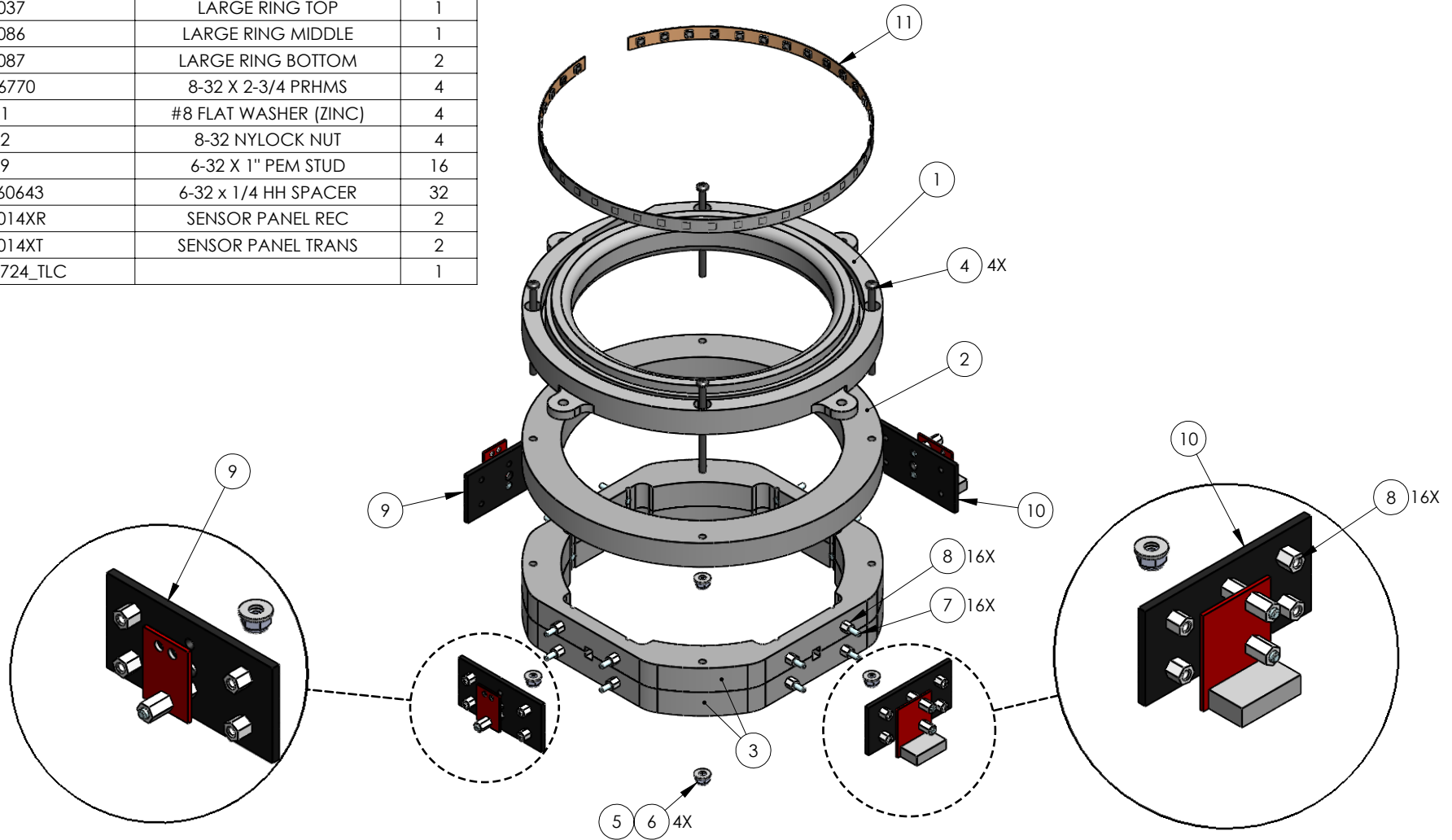

NOTES:

1. DEBURR ALL SHARP EDGES AND BREAK ALL SHARP CORNERS.
2. ALL BENDS MIN. RADIUS UNLESS SPECIFIED

01				9/19/2016	
REV.	DESCRIPTION	ECN#	BY	DATE	
 INNOVATIVE CONCEPTS IN ENTERTAINMENT 10123 Main Street Clarence, NY 14031 Research & Development: FAX: (716) 759-7907 TEL: (716) 759-0370					
DEBURR EDGES, NO TOOL MARKS ON VISIBLE AREAS		TITLE:		MODEL REV:	
INSIDE RADIUS- ROUTERED CORNERS		LARGE TARGET AREA		07	
THREE PLACE DECIMALS ±0.015		PART NO.: TL3130X			
TWO PLACE DECIMALS ±0.030		DESIGN: MV		06/23/16	
ONE PLACE DECIMALS ±0.060		DRAWN: MV		06/23/16	
ANGULAR - BENDS ± 2°		SCALE: 1:4		TO 'A' SIZE	
FINISH:		DWG. NO.:		TL3037X	
MATERIAL:		SCALE:		1 of 1	
				01	

THIS DOCUMENT IS PROPERTY OF I.C.E. AND IS CONSIDERED PROPRIETARY AND CONFIDENTIAL. NO REPRODUCTION OR DISCLOSURE OF THIS DOCUMENT SHALL BE MADE AND THIS DOCUMENT SHALL BE RETURNED INTACT UPON REQUEST.

Weight: Material <not specified>

PRINT DATE: 9/19/2016 FILE LOCATION: D:\Solidworks Vault\TL3037X